

Shear strength of cancellous bone after osteotomy fixed with absorbable self-reinforced polyglycolic acid and poly-L-lactic acid rods

M. J. MANNINEN, U. PÄIVÄRINTA, H. PÄTIÄLÄ, P. ROKKANEN
Department of Orthopaedics and Traumatology, Helsinki University Central Hospital, Helsinki, Finland

R. TAURIO, M. TAMMINMÄKI, P. TÖRMÄLÄ
Biomaterials Laboratory, Tampere University of Technology, Tampere, Finland

The right distal femur of 42 adult rabbits was osteotomized and fixed with two 1.5 mm in diameter metallic Kirschner wires, self-reinforced polyglycolic acid (SR-PGA, Biofix®), or self-reinforced poly-L-lactic acid (SR-PLLA) rods. Follow-up times were 6 and 12 weeks. The shear strength of 30 pairs of femora was investigated. The strength of osteotomized bones was compared with the non-osteotomized controls. After six weeks the operated femora had reached 70, 69 and 71% shear strength in metallic, SR-PGA and SR-PLLA groups, respectively. After 12 weeks the shear strength values were 75, 79 and 73%, respectively. There was no statistically significant difference in shear strength values between the groups. Twelve pairs of femora were studied with microradiographic, oxytetracyclic fluorescence, and histologic methods. Normal bone healing was seen in these samples. Metallic and SR-PLLA implants caused slight foreign-body reaction with giant cells and SR-PGA rods led to slight infiltration of macrophages and foam cells.

1. Introduction

Absorbable polyglycolic acid (PGA) sutures (Dexon®, Davis & Geck) have been commercially available since 1970. Nowadays PGA is widely used in soft tissue surgery; it has also been used for fracture fixation in clinical studies as self-reinforced (SR) rods [2, 13, 19] and screws [17]. The use of SR-PGA devices in bone surgery is limited to cancellous bone because its strength is rapidly lost in tissue [25, 26]. Another biodegradable polyester suitable for fracture fixation is polylactic acid (PLA). From the early 1970s PLA isomers, like poly-DL-lactic acid (PDLA), and poly-L-lactic acid (PLLA), have been used as sutures [4], rods [15, 16], sheets [5], and plates and screws [1, 7, 8] to fix fractures and experimental osteotomies. PLA has been used mainly in veterinary and experimental studies. The first clinical trials with the SR-PLLA screws are currently being performed [17].

The totally biodegradable polymers have been proved to be biocompatible and well-tolerated by soft and bone tissue [6, 7, 12, 14-16, 23]. The mechanically strongest fixation devices have been made by self-reinforcing techniques [25]: the molecularly highly oriented polymer-fibres with a matrix from the same material are transformed into the rods, screws or plates at high temperatures and pressures [18, 22]. The mean initial bending strength of 2.0 mm in diameter SR-PGA rod is 260 MPa, the bending modulus is 10 GPa, and the shear strength is 190 MPa; the shear

strength of the rod decreases to the level of cancellous bone in four to five weeks in the subcutis of rabbit [18]. PLLA has been reported to have better strength characteristics than PDLA and thus it is more suitable for internal fixation devices [9, 16, 28]. The mean initial bending strength of 2.0 mm in diameter SR-PLLA rod is 180 MPa, bending modulus 7 GPa, and shear strength 110 MPa, and the rod loses its mechanical properties after 48 weeks [18].

The results of treatment of cancellous bone fractures, osteotomies, and arthrodeses using Kirschner wire fixation have been good. Often the Kirschner wires tend to move from the drill holes and they cause discomfort to the operated patient by pressing the skin or the nerves until the wires are removed. The benefit of absorbable fixation devices is that no removal operation is required.

The purpose of the present study was to investigate whether the mechanical strength of cancellous bone after experimental osteotomy fixed with the absorbable SR-PGA or SR-PLLA rods is as good as with the Kirschner wire fixation.

2. Materials and methods

2.1. Experimental animals, anesthesia and operation

Forty-two conventionally grown adult rabbits weighing over 2.5 kg were used. They were anesthetized

with subcutaneous ketamine (Ketalar®, Parke-Davis) 30–40 mg kg⁻¹, medetomidine (Domitor®, Lääkefarmos) 0.2–0.3 mg kg⁻¹, and diazepam (Diapam®, Orion) 1.0 mg kg⁻¹. Atropin (Atropin®, Orion) 0.5 mg kg⁻¹ was given subcutaneously to prevent bronchospasm. Preoperatively 50000 IU/kg procain penicillin (Procopen®, Orion) was given as an infection prophylaxis.

The right knee was shaved and scrubbed with 80% ethanol. A medial parapatellar arthrotomy was made and the patella was dislocated laterally. The distal femur was exposed and the cancellous bone osteotomy was made with a diamond saw so that there was no bone connection between the fragments (Fig. 1). After reduction two 1.5 mm holes were drilled from the intercondylar space to the medial and lateral cortex of the femur (Fig. 1). The osteotomy was fixed with two 1.5 mm in diameter metallic rods (Kirschner wire), two ethylene oxide sterilized SR-PGA rods (Biofix®), or two gamma-sterilized (dosage 2.5 Mrad) SR-PLLA rods (material: Boehringer-Ingelheim, M_w 250 000, rods made by Tampere University of Technology). The incision was closed in layers by 3-0 PGA sutures (Dexon®).

2.2. Postoperative care, killing and specimens

No postoperative external support was used and the rabbits were allowed to move freely in their cages. After a follow-up time of six or 12 weeks the rabbits were killed, and both femora were exarticulated, dissected and radiographed. The shear strength values of 30 pairs of femora were investigated. Twelve pairs were evaluated by microradiographic, oxytetracycline-fluorescence, and histologic analysis (Table I). Two days before killing, the rabbits in the histologic group were injected with oxytetracycline (OTC, Terramycin®, Pfizer) 50 mg kg⁻¹ day⁻¹ intramuscularly, for OTC-fluorescence studies.

2.3. Examination methods

Both femora were radiographed in the anteroposterior and medial projections (target-tube distance 120 cm, exposure factors 40 kV, 12 mAs, 0.03 s). The visibility of the osteotomy line, the callus formation, malpositions and the final healing of osteotomy were examined from the radiographs.

The shear force was measured within 30 h from the killing; the specimens were retained in 20 °C 0.9%

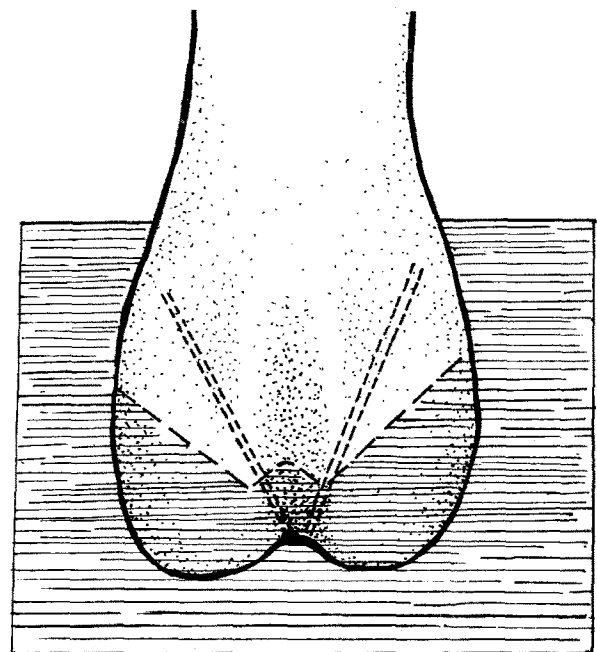

(a)

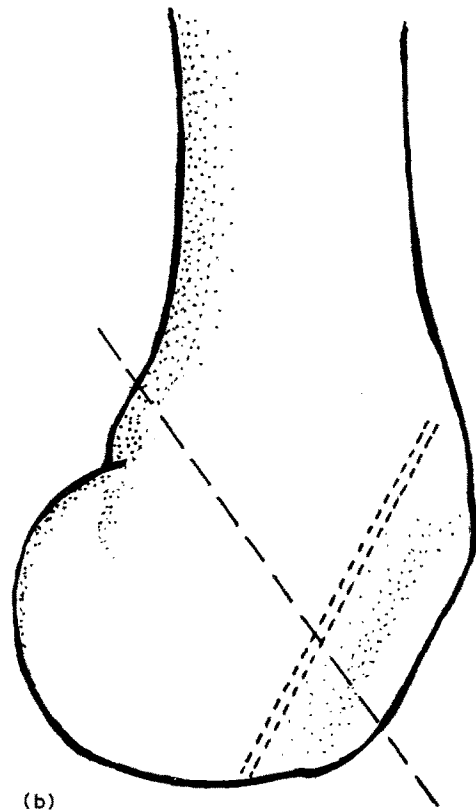

(b)

Figure 1 Right femur of rabbit in (a) anterior and (b) lateral views. Osteotomy line is shown by dashed line and fixation rods by double dashed lines.

TABLE I Examination groups and number of rabbits

Examination method	Follow-up time (weeks)	Fixation material			Total
		Met	PGA	PLLA	
Shear strength	6	5	5	5	15
MRG, OTC, histol.	6	2	2	2	6
Shear strength	12	5	5	5	15
MRG, OTC, histol.	12	2	2	2	6
Total		14	14	14	42

Met: metal (Kirschner-wire), PGA: SR-polyglycolide, PLLA: SR-poly-L-lactide, Shear strength: shear strength analysis, MRG: microradiographical analysis, OTC: oxytetracycline-fluorescence analysis, histol.: histological analysis.

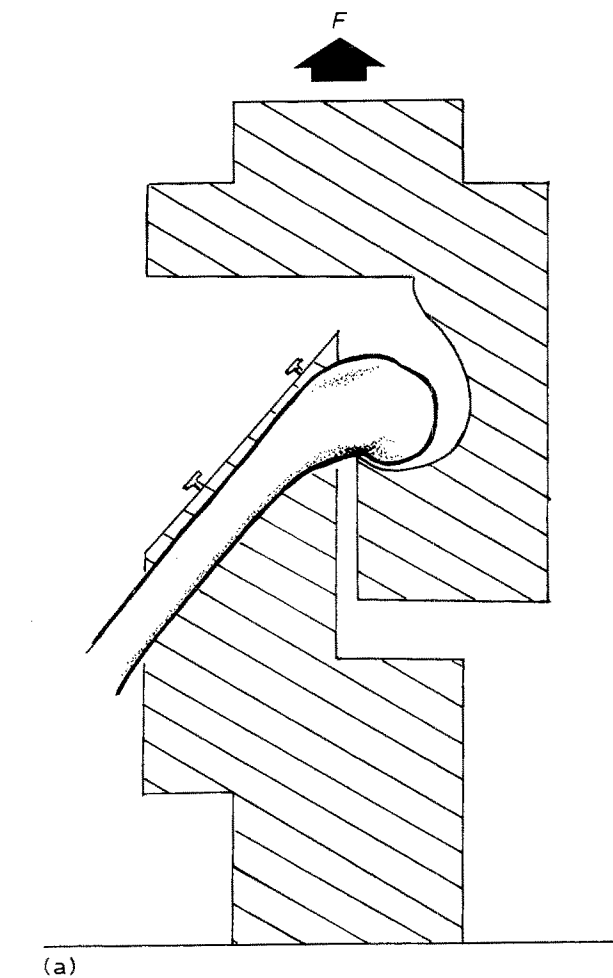

(a)

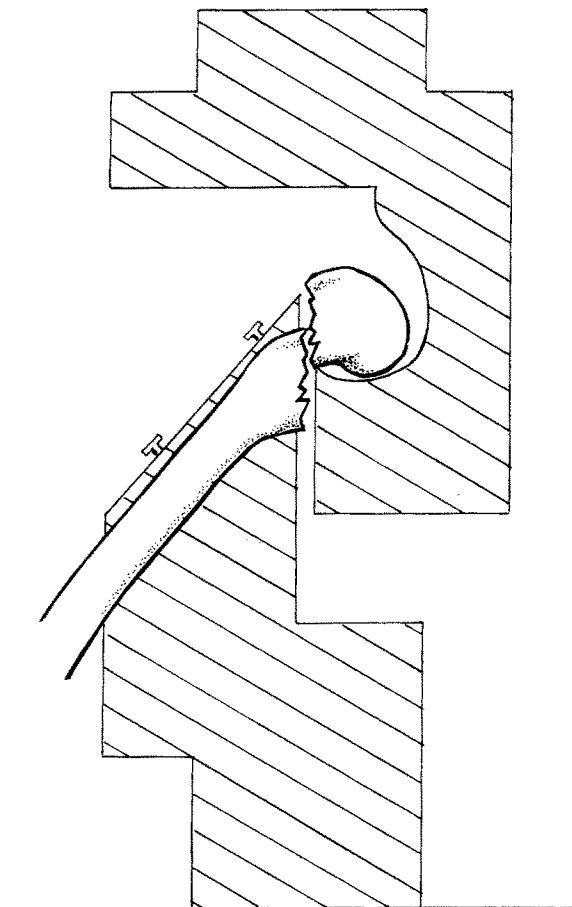

(b)

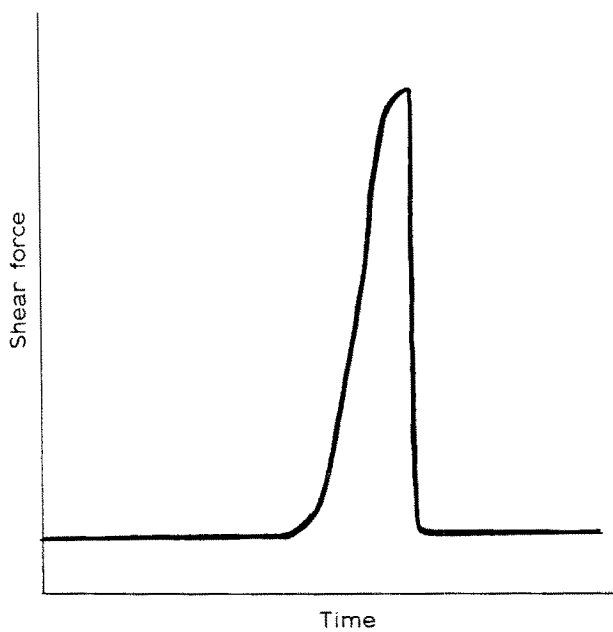

(c)

Figure 2 Shear force measurement with tensile testing equipment JJ 5003 (a) measuring begins, (b) the broken bone, and (c) a typical force against time curve.

tomy line and the left non-operated femora were tested in a similar way (Fig. 2). The shear strength, σ , was calculated using

$$\sigma = F/A$$

where F is the shear force at the fracture and A is the surface area which was determined from the photographs taken of the shear surface. The shear forces and strengths of the osteotomized femora were divided by those of non-osteotomized controls, thus giving comparative forces and strengths.

For microradiographic, OTC-fluorescence, and histologic analysis, the distal third femora of 12 rabbits was fixed in 70% ethanol and embedded in methylmethacrylate. For microradiographic and OTC-fluorescence studies, longitudinal 80 μm thick sections were cut with a saw microtome (Leitz 1600). For histologic analysis 5 μm thick sections were cut with a Jung Polycut S-microtome and stained using Masson-Goldner's method.

For statistical analysis, two way analysis of variance analysis and Student's t -test with two tailed interpretation were used.

3. Results

3.1. Shear forces and strengths

The shear force and strength values are presented in Table II. The mean shear strength of the normal

NaCl solution. Before testing, all metal and PLLA implants were taken away to avoid increasing forces because of implants. In one bone in the six-week PLLA group it was impossible to remove the rods without breaking the bone and they were thus inside the drill holes during the measurement (Table II). The shear force, F , was measured using JJ 5003 tensile testing equipment (J. J. Lloyd Instruments, England) with a testing speed of 10 mm min⁻¹ at 20°C. The osteotomized femora were tested through the osteo-

femoral cancellous bone of rabbit (control femora) was 6.1 (SD 1.6, range 2.3–9.3) MPa. After 6 weeks the shear strength of all osteotomized femora was 3.9 (SD 1.2, range 2.7–6.2) MPa, and after 12 weeks it was 5.0 (SD 1.5, range 3.8–7.2) MPa. After 6 weeks the osteotomized femora had reached 70% comparative shear strength, and after 12 weeks it was 76%. No statistically significant differences were found between

metal, SR-PGA, and SR-PLLA-groups. All groups showed statistically significant increase of strength between 6 and 12 weeks ($p < 0.05$).

3.2. Radiographic results

Radiographically all fixations succeeded. No malpositions were found. After 6 weeks (Fig. 3) the osteotomy

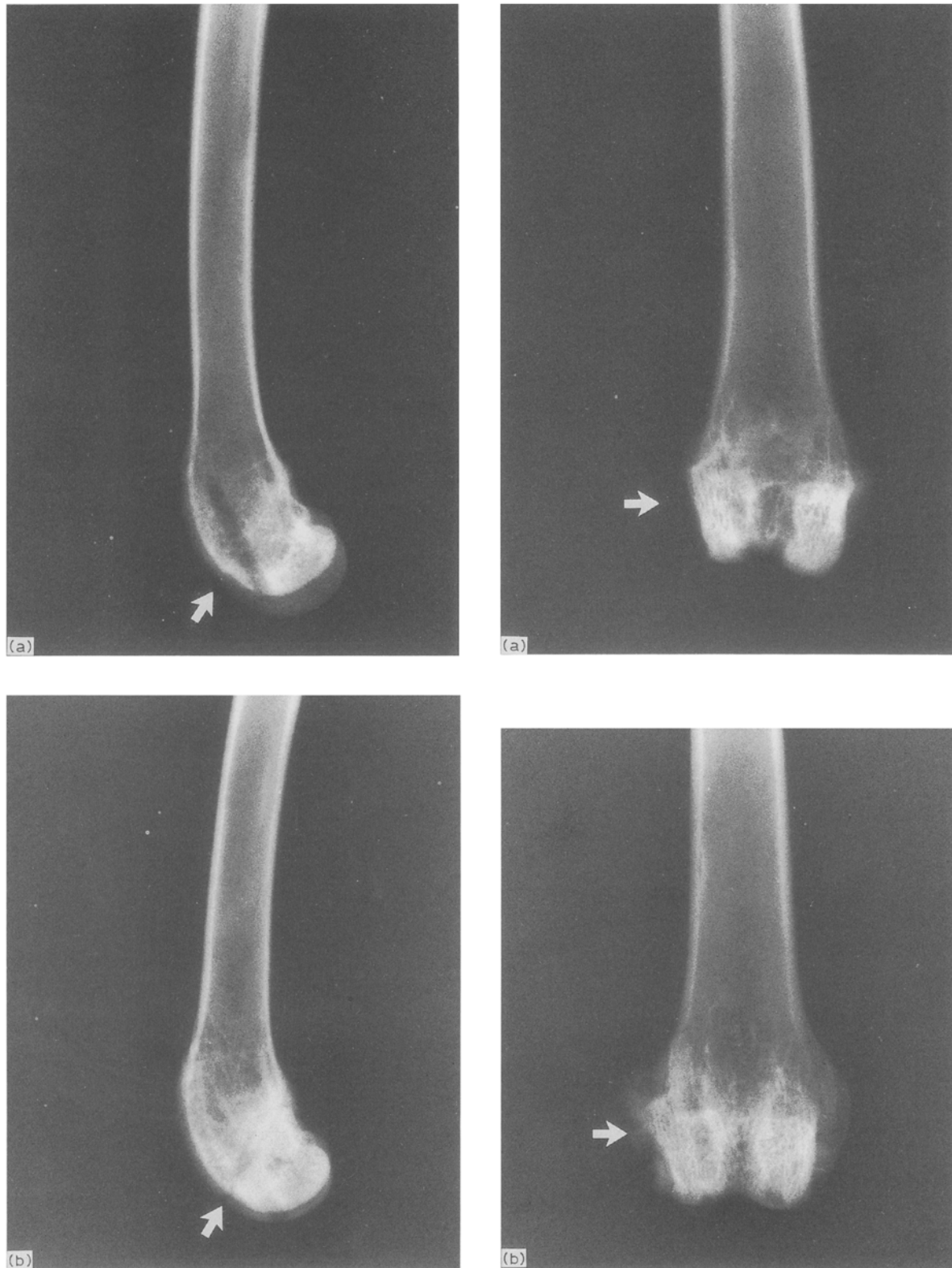

Figure 3 Antero-posterior and medial radiographs of operated femora at six weeks. Arrows indicate the places of osteotomies. (a) Kirschner wire, (b) SR-polyglycolide rod, and (c) SR-poly-L-lactide rod fixation. Note the clearly visible fixation rod channels in (a), osteotomy line and moderate external callus in (b).

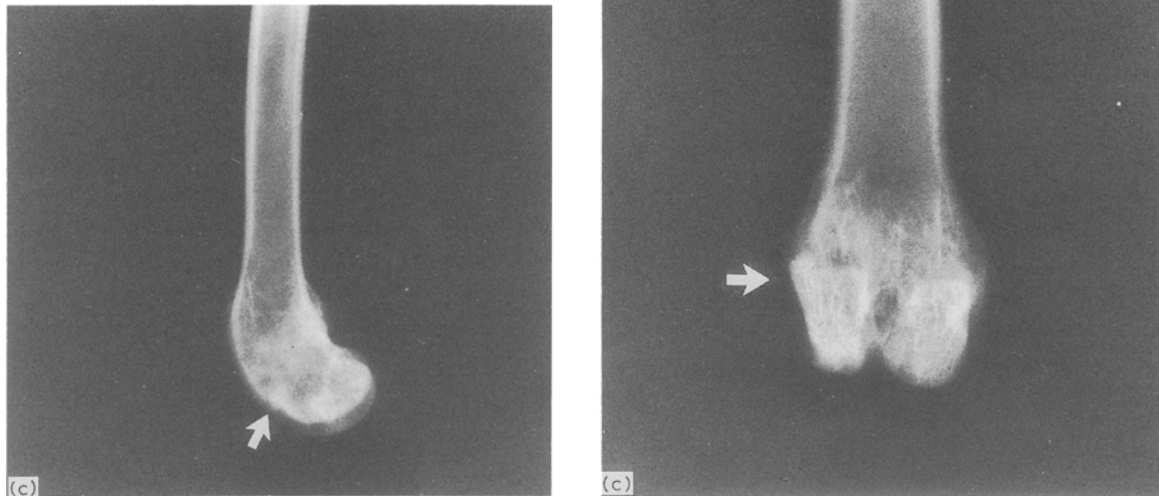

Figure 3 Continued

TABLE II Mean shear forces and strengths and comparative values

Fixation material	Met	PGA	PLLA	Met	PGA	PLLA
Follow-up (weeks)	6	6	6	12	12	12
Number of animals	5	5	5	5	5	5
F_o [SD]	678 [256]	488 [101]	647 [210]	615 [169]	804 [136]	578 [111]
F_c [SD]	774 [210]	632 [218]	770 [202]	726 [127]	868 [128]	652 [147]
F_o/F_c (%)	88	77	84	85	93	89
σ_o [SD] (MPa)	4.2 [1.2]	3.7 [1.3]	4.0 [0.9]	4.9 [2.0]	5.9 [1.4]	4.2 [0.6]
σ_c [SD] (MPa)	6.0 [1.1]	5.4 [1.7]	5.6 [1.4]	6.5 [1.7]	7.4 [1.3]	5.8 [2.2]
σ_o/σ_c (%)	70	69	71	75	79	73

Met: metal (Kirschner-wire), PGA: SR-polyglycolide, PLLA: SR-poly-L-lactide. In 6 weeks PLLA group, PLLA rods were sheared within the bone in one case out of five. F_o : Mean shear force of the osteotomized femurs at the fracture, F_c : Mean shear force of the control femurs at the fracture, σ_o : Mean shear strength of the osteotomized femurs, σ_c : Mean shear strength of the control femurs; SD: One standard deviation.

was most visible in SR-PGA group ($p < 0.05$), and after 12 weeks there were no differences. Callus formation and final healing of osteotomy did not show any differences between the groups.

3.3. Microradiographic, OTC-fluorescence, and histologic results

At six weeks, microradiographic analysis (six rabbits) showed complete union in five fixations and one nearly complete union in the SR-PGA-group. New bone was extracortically observed in every sample. OTC-fluorescence studies showed increased uptake along the osteotomy line, in the periosteal area, and around the implant in every sample and there were no significant differences between the groups. Histologic analysis revealed some connective tissue around the implants in every group. Foreign-body reaction and macrophages were seen around the implant holes in the metal group. In one PGA-sample, proximally from

the osteotomy line, there was a little inflammatory focus containing mainly lymphoblasts from the bone marrow and some lymphocytes. Some liponecrosis was seen in this inflammatory area. Macrophages and foam-cells were found in the PGA-group and in PLLA-samples one giant cell was observed.

At 12 weeks, microradiographically complete union was seen in five of six fixations and one nearly complete union in the SR-PGA-group. New bone was extracortically observed in every sample. In the OTC-fluorescence analysis an increased uptake was noticed periosteally, in the osteotomy line, and around the implants. Histologically some connective tissue was seen surrounding the implants in every sample but no inflammation was found. Some active osteoblasts, in the implant hole, and a few giant cells could be seen in the metal group. In the PGA-group many foam cells were seen full of the PGA-material. Reinforcing PLLA fibres with granulation tissue and capillaries intruding between them were observed in one PLLA sample. No inflammation was noticed in the PLLA group.

4. Discussion

For an orthopaedic surgeon the most interesting factor in bone healing is the time required for the bone to repair its strength to bear the forces caused by movements and the mass of the body.

The mechanical properties of cancellous bone varies a lot as a function of anatomic position and loading direction. The most commonly studied mechanical factor of trabecular bone is compressive strength. It varies from 0.03 to 310 MPa (mainly between 1–15 MPa) when measured from fresh or fresh frozen samples of human bones [10]. The elastic modulus of cancellous bone varies from 1.1 to 9800 MPa in different places in the human skeleton [10].

Studies concerning the shear properties of cancellous bone are rare. Halawa *et al.* [11] investigated the shear strength of human femur and the strength values varied between 1 and 17 MPa. Saha and Gorman [20] measured shear strengths of human femoral samples: the strength of proximal cancellous bone was 4.6 MPa (SD 3.1) and in distal part 3.7 MPa (SD 1.9). Shear strength of bovine humeral trabecular bone is reported to be 6.6 MPa (SD 1.7) [21]. Claes *et al.* [3] studied the shear strength of subchondral cancellous bone of the femoral condyles of sheep. The strength of the normal bone was 11.5 MPa (SD 2.1) and three months after osteotomy fixed by three polydioxanone pins it had reached 80% (mean 9.5, SD 4.0 MPa) of its initial strength. In the present study the mean shear strength of rabbit's intact distal femoral cancellous bone was 6.1 MPa (SD 1.6). Six weeks after the osteotomy the strength of the bone was 70% of the strength of non-operated controls, and after 12 weeks it was 76%.

The comparative shear forces were higher than shear strengths: 83% after 6 weeks and 89% after 12 weeks. First the damaged bone builds abundantly connective tissue and weak cancellous bone thus quickly getting stronger and the force required to break the bone increases. After this it is time for remodelling and the microstructure of the bone organises responding to the stress, and so the bone yields its initial strength.

The left unoperated femur was used as a strength control. White *et al.* [29] wanted to resolve if the contralateral bones are comparable. They tested humeri and tibiofibulae of 34 rabbits by torsional loading. No pattern of right or left dominance emerged. Statistical analysis showed that the observed differences were probably due to biologically normal variation. White *et al.* also demonstrated that the use of a paired experimental design is more efficient than an unpaired design in terms of the number of animals required to achieve a given level of statistical significance. In the present study, cancellous bone was investigated instead of cortical bone, but it was supposed that the same principle applies.

The radiographic results were good, and this supports the results reported before in both experimental [24] and clinical studies [2, 13, 25]. The visibility of the osteotomy line was significantly better in the 6 week SR-PGA group than in the other groups. This could be interpreted as being caused by too rapidly

decreasing strength of SR-PGA, facilitating micro-movements in the osteotomy plane. However, this radiographic difference had no correspondence in the shear strengths. Microradiographic and OTC-labelling analysis showed normal bone healing and revealed no differences between the metallic, SR-PGA or SR-PLLA fixing groups. Similar results have been reported by Vainionpää *et al.* [24], Vasenius *et al.* [27], and Majola *et al.* [16].

The PGA material evoked only a minimal inflammatory response in rat subcutis [12]. No signs of delayed inflammation reaction or foreign-body reaction were observed in studies with PGA implanted in bone tissue [23, 27]. One inflammatory reaction with lymphoblasts and lymphocytes was found in one SR-PGA sample. Some liponecrosis was seen in this inflammatory area; it was thought that this necrotic area was the cause of inflammation and the presence of cells from the bone marrow. It has been reported that PLA induces a mild foreign-body reaction with a few giant cells [4, 14, 16]. This giant cell reaction was also observed with PLLA and metallic implants.

When compared with the Kirschner wire fixation it seems that using the absorbable SR-PGA and SR-PLLA rods does not have an effect on the healing of bone as a weight and stress bearing structure.

Acknowledgements

This study was supported by grants from the Academy of Finland and the Foundation of Orthopaedics and Traumatology. The authors would like to thank Matti Kataja, Kalevi Lauslahti and Terttu Toivonen for their advice.

References

1. R. R. M. BOS, G. BOERING, F. R. ROZEMA, J. W. LEENSLAG, A. J. PENNING and A. B. VERWEY, *J. Oral Maxillofac. Surg.* **45** (1987) 751.
2. O. BÖSTMAN, S. VAINIONPÄÄ, E. HIRVENSALO, A. MÄKELÄ, K. VIHTONEN, P. TÖRMÄLÄ and P. ROKKANEN, *J. Bone Joint Surg.* **69B** (1987) 615.
3. L. CLAES, C. BURRI, H. KIEFER and W. MUTCHER, *Akt. Traumatol.* **16** (1986) 74.
4. D. E. CUTRIGHT, E. E. HUNSUCK and J. D. BEASLEY, *J. Oral Surg.* **29** (1971) 393.
5. D. E. CUTRIGHT and E. E. HUNSUCK, *Oral Surg.* **33** (1972) 28.
6. D. E. CUTRIGHT, B. PEREZ, J. D. BEASLEY, W. J. LARSON and W. R. POSEY, *Oral Surg.* **37** (1974) 142.
7. J. EITENMÜLLER, K. L. GERLACH, T. SCHMICKAL and G. MUHR, *Chirurg* **58** (1987) 831.
8. L. GÖTTER, D. E. CUTRIGHT, S. N. BHASKAR and J. K. AUGSBURG, *J. Oral Surg.* **30** (1972) 344.
9. K. L. GERLACH and J. EITENMÜLLER, in *Proceedings of Biomaterials and Clinical Applications*, Amsterdam, 1987, edited by A. Pizzoferrato, P. G. Marchetti, A. Ravaglioli and A. J. C. Lee (Elsevier Science Publishers BV, Amsterdam, 1987) p. 439.
10. S. A. GOLDSTEIN, *J. Biomechanics* **20** (1987) 1055.
11. M. HALAWA, A. J. C. LEE, R. S. M. LING and S. S. VANGALA, *Arch. Orthop. Traumat. Surg.* **92** (1978) 19.
12. J. B. HERMANN, R. J. KELLY and G. A. HIGGINS, *Arch. Surg.* **100** (1970) 486.
13. E. HIRVENSALO, *Acta Orthop. Scand.* **60** (1989) 601.
14. R. K. KULKARNI, K. C. PANI, C. NEUMAN and F. LEONARD, *Arch. Surg.* **93** (1966) 839.

15. R. K. KULKARNI, E. G. MOORE, A. F. HEGYELI and F. LEONARD, *J. Biomed. Mater. Res.* **5** (1971) 169.
16. A. MAJOLA, S. VAINIONPÄÄ, K. VIHTONEN, M. MERO, J. VASENIUS, P. TÖRMÄLÄ, and P. ROKKANEN, *Clin. Orthop.* **286** (1991) 260.
17. E. K. PARTIO, *Unfall Chirurgie*, In press.
18. T. POHJONEN, P. TÖRMÄLÄ, J. MIKKOLA, J. LAIHO, P. HELEVIRTA, H. LÄHDE, S. VAINIONPÄÄ and P. ROKKANEN, in Abstracts of VIth International Conference PIMS (Polymers in Medicine and Surgery), Leeuwenhorst Congress Centre, Holland, April 1989, p. 34/1.
19. P. ROKKANEN, O. BÖSTMAN, S. VAINIONPÄÄ, K. VIHTONEN, P. TÖRMÄLÄ, J. LAIHO, J. KILPIKARI and M. TAMMINMÄKI, *Lancet* no. 8443, Vol. I (1985) 1422.
20. S. SAHA and P. H. GORMAN, *Orthop. Transact.* **5** (1981) 217.
21. J. L. STONE, G. S. BEAUPRE and W. C. HAYES, *J. Biomechanics* **16** (1983) 743.
22. P. TÖRMÄLÄ, P. ROKKANEN, J. LAIHO, M. TAMMINMÄKI and S. VAINIONPÄÄ, US Patent 4743257 (1988).
23. S. VAINIONPÄÄ, *Arch. Orthop. Trauma. Surg.* **104** (1986) 333.
24. S. VAINIONPÄÄ, K. VIHTONEN, M. MERO, H. PÄTIÄLÄ, P. ROKKANEN, J. KILPIKARI and P. TÖRMÄLÄ, *Arch. Orthop. Trauma. Surg.* **106** (1986) 1.
25. S. VAINIONPÄÄ, P. ROKKANEN and P. TÖRMÄLÄ, *Prog. Polym. Sci.* **14** (1989) 679.
26. J. VASENIUS, S. VAINIONPÄÄ, K. VIHTONEN, A. MÄKELÄ, P. ROKKANEN, M. MERO and P. TÖRMÄLÄ, *Biomaterials* **11** (1990) 501.
27. J. VASENIUS, S. VAINIONPÄÄ, K. VIHTONEN, M. MERO, A. MÄKELÄ, P. TÖRMÄLÄ and P. ROKKANEN, *J. Biomed. Mater. Res.* **24** (1990) 1615.
28. M. VERT and F. CHABOT, *Makromol. Chem., Suppl.* **5** (1981) 30.
29. A. A. WHITE, M. M. PANJABI and R. J. HARDY, *Acta Orthop. Scand.* **45** (1974) 328.

*Received 6 February
and accepted 5 March 1991*